

Genetic Testing for Dilated Cardiomyopathy

This pamphlet tries to answer some questions about the genetics of Dilated Cardiomyopathy and genetic testing for Dilated Cardiomyopathy. The internet also offers many good resources for learning more about these topics. Please visit our website at www.correlagen.com for more information on genetic testing and on Dilated Cardiomyopathy and for links to many other websites with information on these topics, or call us at 1-866-647-0735.

What is an inherited disorder

Inherited disorders are caused primarily by variations in a gene sequence rather than by environmental influences. Since genes and any variations in these genes are passed on within families, an inherited disorder is also passed on within families. Depending on the associated gene, an inherited disorder can show autosomal dominant, autosomal recessive, X-linked dominant, or X-linked recessive inheritance. Dilated Cardiomyopathy typically shows autosomal dominant inheritance.

What is autosomal dominant inheritance?

Autosomally inherited disorders are associated with genes that are present in two copies per cell in both males and females. One copy of each autosomal gene is inherited from the mother, and the other from the father. **Dominantly** inherited disorders can develop as soon as a disease-associated genetic variation (also called a mutation) is present on either the gene copy inherited from the father or the gene copy inherited from the mother. **Autosomal dominant** disorders are typically seen in every generation. Affected parents will pass an autosomal dominant disorder to, on average, half of their sons and half of their daughters.

What is inheritance with low penetrance?

Disease-associated genetic variations with low penetrance do not cause disease in all individuals. However, even if an individual harboring a disease-associated mutation never develops the disorder, he or she can still pass on the disease-associated mutation to his or her children, who may then develop the disorder. Dominant disorders that show low penetrance may seem to “skip” generations.

What is genetic testing?

Genetic testing is a method for diagnosing inherited disorders. Genetic testing detects genetic variations in a gene sequence. Since inherited disorders are associated with certain disease-causing genetic variations (also called mutations), finding such disease-associated variations in an individual's genes can allow diagnosis of the disorder or indicate a greatly increased risk of developing the disorder. The vast majority of inherited disorders can be caused by any one of many different genetic variations within one specific gene or within any one of several specific genes. Therefore, genetic testing involves screening all those regions of a gene (or of several genes) where genetic variation most often leads to disease. This type of genetic testing is also known as full-gene sequencing. Even full-gene sequencing, however, cannot guarantee detection of all disease-associated variations. Failure to find a disease-associated variation can mean one of three things: (1) The patient is affected by the inherited disorder, but the disease-associated variation is located in a gene that was not included in the test. (2) The patient is affected by the inherited disorder, but the disease-associated variation in this patient is of a special type that cannot be detected by the testing method used. (3) The patient is not affected by the inherited disorder. For these reasons, genetic testing **can only confirm, but not exclude** presence of a disorder or high risk of developing a disorder. (An exception to this rule is genetic family testing, which can both confirm and exclude presence or risk of the inherited disorder - see below for more information on genetic family testing.)

What are variants of unknown significance and possible disease variants?

A genetic variation (or variant) of unknown significance may or may not be associated with disease. A possible disease variant is suspected to be associated with disease, but this association remains quite uncertain. More information is needed to clarify the significance of such genetic variations. Over time, this information may become available in the literature. Genetic testing of affected individuals within the patient's extended family (known as concordance testing) may also yield this information. If all affected family members harbor the genetic variation in question, it is likely to be associated with the inherited disorder. If

some affected family members do not harbor the genetic variation in question, it is less likely to be associated with the inherited disorder. Clarifying the significance of a genetic variation through concordance testing in a family not only benefits this particular family, but also other families who harbor the same genetic variation.

Does a variation found in a gene associated with an inherited disorder have to be disease-causing?

Not all variations in a gene associated with an inherited disorder are disease causing. Some variations are harmless (such variations are also referred to as polymorphisms). Harmless variations typically occur at high frequency in the general population (ie, individuals with or without the inherited disorder).

Can genetic testing predict severity of a disorder?

Genetic testing can usually not predict severity of a disorder. Typically, the results of genetic testing only indicate the probability or risk of disease. In other words, a genetic variation definitively known to be associated with a disorder may cause mild symptoms, while a genetic variation only suspected to be associated with a disorder may cause particularly severe symptoms. In some cases, however, the nature or the location of a genetic variation can allow some general predictions about the severity of symptoms.

What is genetic family testing?

Genetic family testing can both confirm and exclude presence or high risk of the familial disorder in members of an affected family, by detecting presence or absence of the familial mutation. The familial mutation is the specific genetic variation that causes all cases of an inherited disorder within one extended family. Why are related patients likely to harbor the same disease-associated mutation, given that two unrelated patients with the same inherited disorder typically harbor two completely different disease-associated mutations? If a parent harbors a disease-associated mutation, his or her children each have a 1 in 2 chance of inheriting the parental mutation. In contrast, the general risk of harboring a disease-associated mutation is much lower (<1:100 for most inherited disorders). It is therefore much more likely that members of a family affected with an inherited disorder inherit the familial mutation than that they harbor a different disease-associated mutation. Once a familial mutation is known, this knowledge stays within the family forever and can facilitate diagnosis of the inherited disorder through many generations.

Importantly, absence of the familial mutation can only rule out the inherited disorder in family members of the index patient if the familial mutation is known to be or very likely to be disease associated. Correlagen assesses such mutations (or variants) as “associated with” or “probably associated with” disease. Sometimes, a variant assessed as “possibly associated with” disease is suspected to be the familial mutation. Absence of such a possible disease variant cannot rule out the inherited disorder in family members of the index patient, since it is not certain that this variant is the cause of the inherited disorder in this family.

What are the benefits of genetic family testing?

Genetic family testing for dominant disorders can identify both at-risk and not-at-risk family members. If the familial mutation is not present, the family member can be reassured that he or she and his or her descendants are not at any greater risk of the developing the disorder than the general population. If the familial mutation is present, the family member and his or her parents, siblings, and children are at greatly increased risk of developing the disorder. Family members harboring the familial mutation know that they and their physicians have to be vigilant for symptoms of the disorder and seek treatment as soon as symptoms appear.

Genetic testing is often the best tool for identifying both at-risk and not-at-risk family members. For example, a family member without any symptoms of the disorder may be unaffected, or he or she may be presymptomatic – that is, he or she may simply not have developed symptoms of the disorder yet. Sometimes, symptoms may be present, but it may be unclear if they are due to that specific disorder or due to unrelated reasons. It is also possible that an individual harboring a disease-associated mutation never develops symptoms. However, this individual can still pass on the mutation to his or her children, who may then develop the disorder.

Who in the patient's family should be tested?

Ideally, family testing should "radiate" outward from the index patient (the patient in whom the familial mutation was initially identified). The recommended testing sequence for an autosomal dominant disorder is illustrated in Figures 1A and 1B below. The same hypothetical family tree is shown two times. The index patient is indicated by the arrow. In the first round of genetic family testing (Figure 1A), the children, siblings, and parents of the index patient are tested for presence of the familial mutation. In the example shown here, the father, the son, and one brother harbor the familial mutation, while the mother, the daughter, and the other brother do not harbor the familial mutation. In the second round of genetic testing (Figure 1B), the children of the affected brother (ie, the nieces of the index patient) and the sister of the affected parent (the paternal aunt of the index patient) are tested. Two of the three nieces carry the familial mutation, one does not. The paternal aunt also carries the familial mutation, and her children, the cousins of the index patient, should be tested next. Note that only blood relatives of the index patient need to be tested! Relatives by marriage or adoption are not at risk of harboring the familial mutation found in the index patient.

Figure 1A: 1st round of genetic family testing

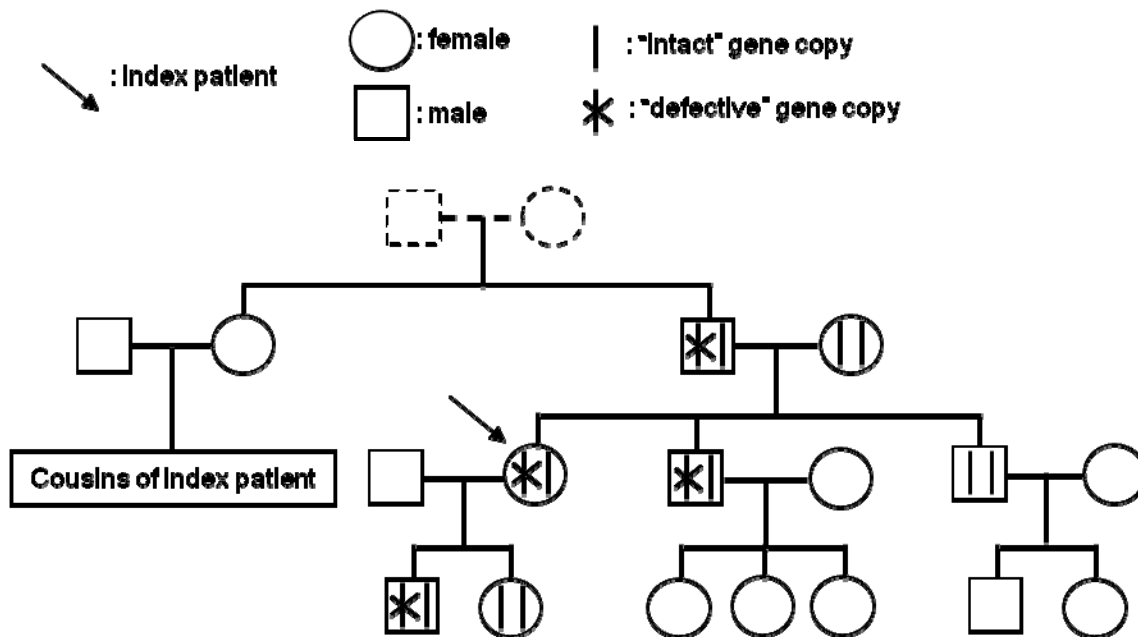
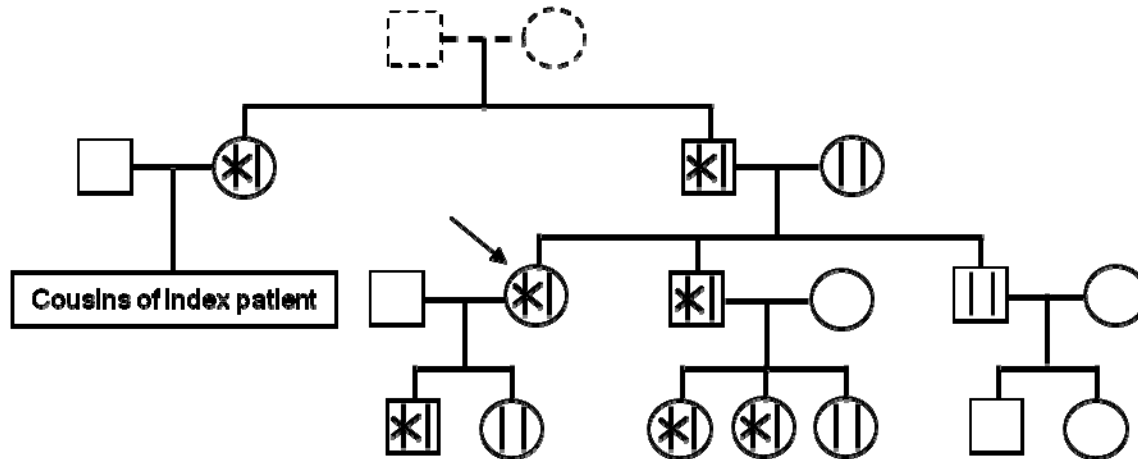

Figure 1B: 2nd round of genetic family testing



The meaning of mosaicism

Mosaicism means that a certain genetic variation does not occur in all cells of the body, but only in some. In other words, an individual can be a "mosaic" of cells that harbor the genetic variation and cells that do not harbor the genetic variation. Genetic testing may or may not be able to detect a genetic variation in a mosaic individual, depending on how many cells and which cells harbor the genetic variation. The risk of inheriting a disease-associated genetic variation from a mosaic individual varies widely and cannot be predicted.

The meaning of "de novo" genetic variation

Sometimes, a disease-associated genetic variation is newly generated in an individual. In other words, an inherited disorder can suddenly appear within a member of a previously unaffected family. The descendants of the affected family member are then at high risk of inheriting the newly generated familial mutation. In addition, the siblings of the affected family member may also be at increased risk of the disorder, since the familial mutation may, in fact, have originated in one of the patient's parents – ie, one of the parents could be a mosaic for the genetic variation. It is therefore important to consider genetic testing of the index patient's siblings even if the genetic variation found in the index patient cannot be detected in either parent.

Where can I get more information on genetic testing or on Dilated Cardiomyopathy?

To learn more about genetic testing in general or about Dilated Cardiomyopathy, please visit **Correlagen's website** at www.correlagen.com, e-mail us at info@correlagen.com, or call us at 1-866-647-0735. Information on Dilated Cardiomyopathy can also be found by visiting the websites of the [Children's Cardiomyopathy Foundation](#) or the [C.A.R.E. Foundation](#).

For help with finding a genetic counselor and or with initiating family testing, please visit **Correlagen's website** at www.correlagen.com, e-mail us at info@correlagen.com, or call us at 1-866-647-0735. Correlagen's website also provides information about laws protecting against discrimination based on genetic information.