

Genetic Testing for X-Linked Agammaglobulinemia

This pamphlet tries to answer some questions about the genetics of X-linked Agammaglobulinemia and genetic testing for X-linked Agammaglobulinemia. The internet also offers many good resources for learning more about these topics. Please visit our website at www.correlagen.com for more information on genetic testing and on X-linked Agammaglobulinemia and for links to many other websites with information on these topics, or call us at 1-866-647-0735.

What is an inherited disorder

Inherited disorders are caused primarily by variations in a gene sequence rather than by environmental influences. Since genes and any variations in these genes are passed on within families, an inherited disorder is also passed on within families. Depending on the associated gene, an inherited disorder can show autosomal dominant, autosomal recessive, X-linked dominant, or X-linked recessive inheritance. X-linked Agammaglobulinemia shows X-linked recessive inheritance.

What is X-linked recessive inheritance?

X-linked disorders are associated with genes that are present in two copies per cell in females, but only in one copy per cell in males. Females inherit one copy of each X-linked gene from the mother, and the other copy from the father. In contrast, males inherit one copy of each X-linked gene from the mother, but do not inherit any X-linked genes from their father. **Recessively** inherited disorders only develop if a disease-associated genetic variation (also called a mutation) is present on all available copies of a gene. In females, presence of a disease-associated genetic variation only on the gene copy inherited from the mother or only on the gene copy inherited from the father is usually not sufficient to cause disease, although a subset of symptoms may be present. Females who harbor a disease-associated genetic variation on only one of the two gene copies are called carriers. In males, in contrast, presence of a disease-associated genetic variation on the single gene copy inherited from the mother is sufficient to cause disease. **X-linked recessive** disorders are therefore almost exclusively seen in males. An X-linked recessive disorder may "skip" generations, carried by females. Approximately half of the sons of a carrier mother will be affected by the disorder, and approximately half of the daughters of a carrier mother will also be carriers. Of note, sons can never inherit an X-linked disorder from their father.

What is genetic testing?

Genetic testing is a method for diagnosing inherited disorders. Genetic testing detects genetic variations in a gene sequence. Since inherited disorders are associated with certain disease-causing genetic variations (also called mutations), finding such disease-associated variations in an individual's genes can allow diagnosis of the disorder or indicate a greatly increased risk of developing the disorder. The vast majority of inherited disorders can be caused by any one of many different genetic variations within one specific gene or within any one of several specific genes. Therefore, genetic testing involves screening all those regions of a gene (or of several genes) where genetic variation most often leads to disease. This type of genetic testing is also known as full-gene sequencing. Even full-gene sequencing, however, cannot guarantee detection of all disease-associated variations. Failure to find a disease-associated variation can mean one of three things: (1) The patient is affected by the inherited disorder, but the disease-associated variation is located in a gene that was not included in the test. (2) The patient is affected by the inherited disorder, but the disease-associated variation in this patient is of a special type that cannot be detected by the testing method used. (3) The patient is not affected by the inherited disorder. For these reasons, genetic testing **can only confirm, but not exclude** presence of a disorder or high risk of developing a disorder. (An exception to this rule is genetic family testing, which can both confirm and exclude presence or risk of the inherited disorder - see below for more information on genetic family testing.)

What are variants of unknown significance and possible disease variants?

A genetic variation (or variant) of unknown significance may or may not be associated with disease. A possible disease variant is suspected to be associated with disease, but this association remains quite uncertain. More information is needed to clarify the significance of such genetic variations. Over time, this information may become available in the literature. Genetic testing of affected individuals within the

patient's extended family (known as concordance testing) may also yield this information. If all affected family members harbor the genetic variation in question, it is likely to be associated with the inherited disorder. If some affected family members do not harbor the genetic variation in question, it is less likely to be associated with the inherited disorder. Clarifying the significance of a genetic variation through concordance testing in a family not only benefits this particular family, but also other families who harbor the same genetic variation.

Does a variation found in a gene associated with an inherited disorder have to be disease-causing?

Not all variations in a gene associated with an inherited disorder are disease causing. Some variations are harmless (such variations are also referred to as polymorphisms). Harmless variations typically occur at high frequency in the general population (ie, individuals with or without the inherited disorder).

Can genetic testing predict severity of a disorder?

Genetic testing can usually not predict severity of a disorder. Typically, the results of genetic testing only indicate the probability or risk of disease. In other words, a genetic variation definitively known to be associated with a disorder may cause mild symptoms, while a genetic variation only suspected to be associated with a disorder may cause particularly severe symptoms. In some cases, however, the nature or the location of a genetic variation can allow some general predictions about the severity of symptoms.

What is genetic family testing?

Genetic family testing can both confirm and exclude presence or high risk of the familial disorder in members of an affected family, by detecting presence or absence of the familial mutation. The familial mutation is the specific genetic variation that causes all cases of an inherited disorder within one extended family. Why are related patients likely to harbor the same disease-associated mutation, given that two unrelated patients with the same inherited disorder typically harbor two completely different disease-associated mutations? If a parent harbors a disease-associated mutation, his or her children each have a 1 in 2 chance of inheriting the parental mutation. In contrast, the general risk of harboring a disease-associated mutation is much lower (<1:100 for most inherited disorders). It is therefore much more likely that members of a family affected with an inherited disorder inherit the familial mutation than that they harbor a different disease-associated mutation. Once a familial mutation is known, this knowledge stays within the family forever and can facilitate diagnosis of the inherited disorder through many generations.

Importantly, absence of the familial mutation can only rule out the inherited disorder in family members of the index patient if the familial mutation is known to be or very likely to be disease associated. Correlagen assesses such mutations (or variants) as "associated with" or "probably associated with" disease. Sometimes, a variant assessed as "possibly associated with" disease is suspected to be the familial mutation. Absence of such a possible disease variant cannot rule out the inherited disorder in family members of the index patient, since it is not certain that this variant is the cause of the inherited disorder in this family.

What are the benefits of genetic family testing?

Genetic family testing for X-linked recessive disorders can identify female carriers of disease-associated genetic variations, whose sons are at a 50% risk of being affected with the disorder. Genetic testing is often the best tool for identifying female disease carrier, since they typically do not show any symptoms. Family testing can also be used to identify affected male family members even before symptoms develop.

Who in the patient's family should be tested?

Ideally, family testing should "radiate" outward from the index patient (the patient in whom the familial mutation was initially identified). The recommended testing sequence for an X-linked recessive disorder is illustrated in Figures 1A and B below. The same hypothetical family tree is shown two times. The male index patient is indicated by the arrow. His daughters are "obligate carriers" of the familial mutation, ie, they are certain to harbor the familial mutation. In the first round of genetic family testing (Figure 1A), the mother and the siblings of the index patient are tested for presence of the familial mutation. The father of the index

patient does not need to be tested, because the index patient is male and therefore cannot have inherited the X-linked familial mutation from his father. In the example shown here, the mother and the sister harbor the familial mutation, while the brother does not. In the second round of genetic testing (Figure 1B), the children of the affected sister (ie, the niece and nephew of the index patient) and the sister of the affected parent (the maternal aunt of the index patient) are tested. The nephew harbors the familial mutation, the niece does not. The paternal aunt also harbors the familial mutation, and her children, the cousins of the index patient, should be tested next. Note that only blood relatives of the index patient need to be tested! Relatives by marriage or adoption are not at risk of harboring the familial mutation found in the index patient.

Figure 1A: 1st round of genetic family testing

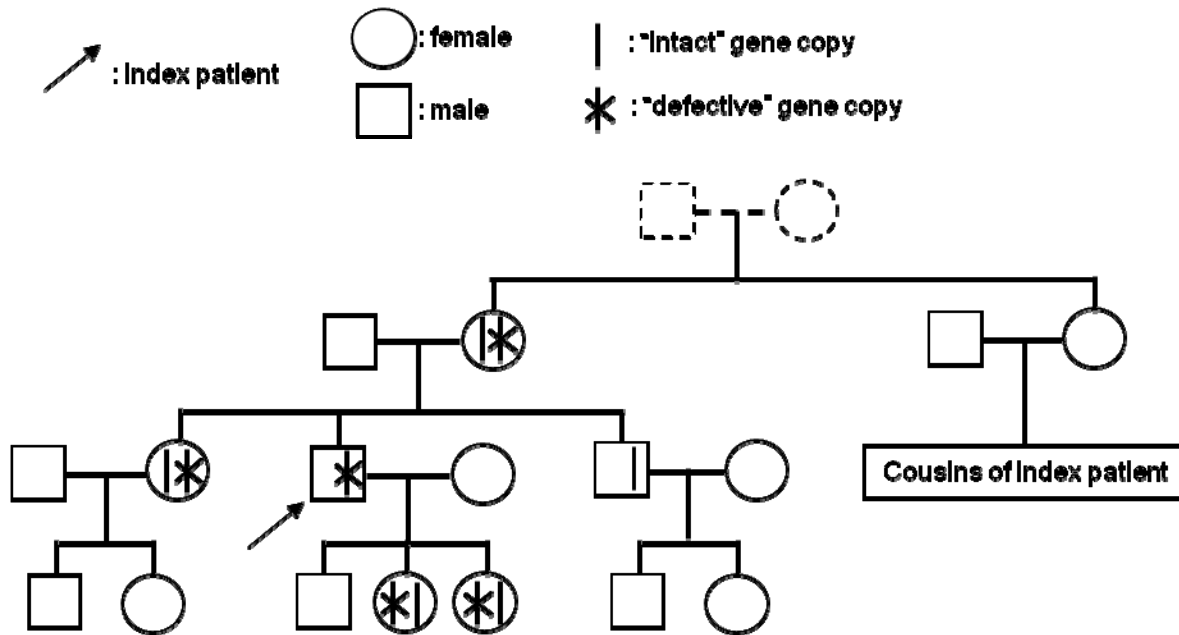
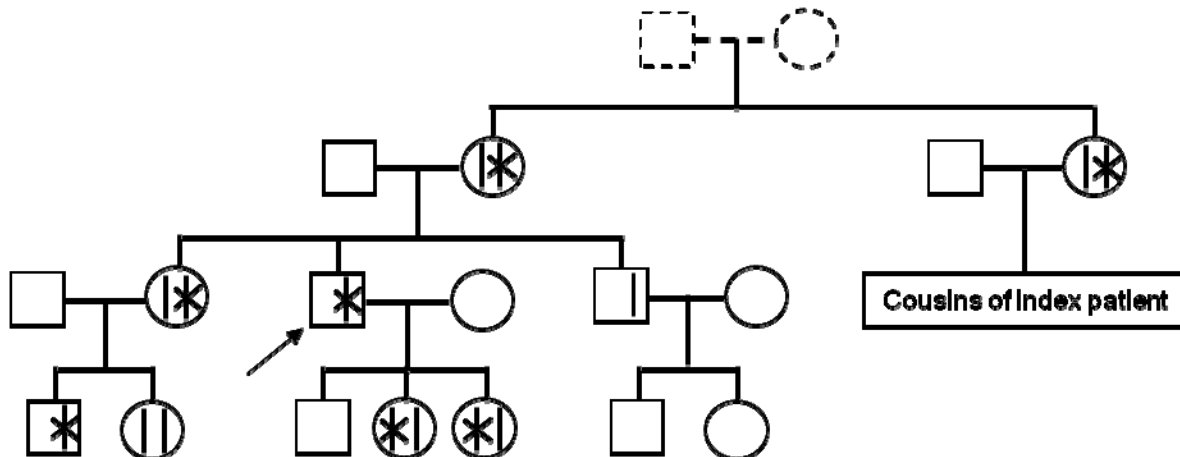

Figure 1B: 2nd round of genetic family testing



The meaning of mosaicism

Mosaicism means that a certain genetic variation does not occur in all cells of the body, but only in some. In other words, an individual can be a "mosaic" of cells that harbor the genetic variation and cells that do not harbor the genetic variation. Genetic testing may or may not be able to detect a genetic variation in a mosaic individual, depending on how many cells and which cells harbor the genetic variation. The risk of inheriting a disease-associated genetic variation from a mosaic individual varies widely and cannot be predicted.

The meaning of "de novo" genetic variation

Sometimes, a disease-associated genetic variation is newly generated in an individual. In other words, an inherited disorder can suddenly appear within a member of a previously unaffected family. The descendants of the affected family member are then at high risk of inheriting the newly generated familial mutation. In addition, the siblings of the affected family member may also be at increased risk of the disorder, since the familial mutation may, in fact, have originated in one of the patient's parents – ie, one of the parents could be a mosaic for the genetic variation. It is therefore important to consider genetic testing of the index patient's siblings even if the genetic variation found in the index patient cannot be detected in either parent.

The meaning of skewed X-inactivation

While females harbor two copies of each X-linked gene, typically only one copy is "active." The other copy becomes permanently inactivated during development. Usually, this "X inactivation" is a random process: In some cells, the gene copy inherited from the mother will be inactivated; in other cells, the gene copy inherited from the father will be inactivated. Skewed X-inactivation is present when either the maternal or the paternal gene copy is preferentially inactivated. If one gene copy harbors a disease-associated genetic variation and the other does not, skewing of X-inactivation towards the unaffected gene copy can lead to development of an X-linked recessive disorder in females. On the other hand, skewing of X-inactivation towards the affected gene copy can prevent even mild disease symptoms in females.

Where can I get more information on genetic testing or on X-linked Agammaglobulinemia?

To learn more about genetic testing in general or about X-linked Agammaglobulinemia, please visit **Correlagen's website** at www.correlagen.com, e-mail us at info@correlagen.com, or call us at 1-866-647-0735. Information on X-linked Agammaglobulinemia can also be found by visiting the websites of [The Jeffrey Modell Foundation](#) and [The Immune Deficiency Foundation](#).

For help with finding a genetic counselor and or with initiating family testing, please visit **Correlagen's website** at www.correlagen.com, e-mail us at info@correlagen.com, or call us at 1-866-647-0735. Correlagen's website also provides information about laws protecting against discrimination based on genetic information.